

## Aluminum Single Point Load Cell

**ATEX**

**FEATURES**

- Capacities 3 - 90kg
- Aluminum construction
- Single point 400 x 400mm platform
- NTEP approved
- IP65 protection
- Available with metric and UNC threads

**OPTIONAL FEATURES**

- EEx ia IIC T4 hazardous area approval
- FM approval available
- IP67 available

**DESCRIPTION**

Model 1010 is a single point load cell designed for direct mounting of low cost, low capacity weighing platforms.

Its use in large platforms, combined with its high accuracy and low cost, makes this load cell ideally suited for a large range of weighing applications, including bench scales and counting scales.

A special humidity resistant protective coating is available which ensures long-term reliability. For hazardous envi-

ronments this load cell has EEx ia IIC T4 level approved option.

Model 1010's built-in overload stop can provide mechanical protection against overloading.

The two additional sense wires feed back the voltage reaching the load cell. Complete compensation of changes in lead resistance due to temperature change and/or cable extension is achieved by feeding this voltage into the appropriate electronics.

**APPLICATIONS**

- Bench scales
- Counting scales
- Grocery scales

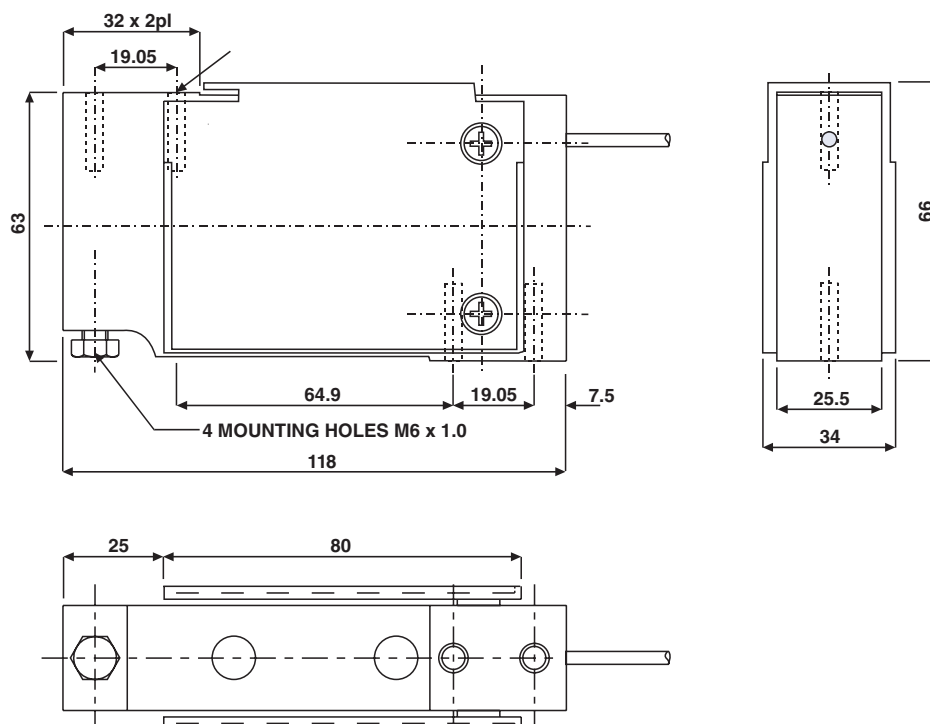
**OUTLINE DIMENSIONS** in millimeters

## SPECIFICATIONS

PARAMETER	VALUE*		UNIT
Rated capacity-R.C. ( $E_{max}$ )	3, 5, 7, 10, 15, 20, 30, 50, 90		kg
NTEP/OIML Accuracy class	NTEP	Non-Approved	
Maximum no. of intervals (n)	5000 single	3000	
$Y = E_{max}/V_{min}$	10000	10000	Maximum available
Rated output-R.O.	2.0		mV/V
Rated output tolerance	0.2		±mV/V
Zero balance	0.2		+mV/V
Zero Return, 30 min.	0.0330	0.0170	±% of applied load
Total Error (per OIML R60)	0.0200	0.0200	±% of rated output
Temperature effect on zero	0.0023	0.004	±% of rated output/°C
Temperature effect on output	0.001	0.0010	±% of applied load/°C
Eccentric loading error	0.0057	0.0049	±% of rated load/cm
Temperature range, compensated	-10 to +40		°C
Temperature range, safe	-20 to +70		°C
Maximum safe central overload	150		% of R.C.
Ultimate central overload	300		% of R.C.
Excitation, recommended	10		Vdc or Vac rms
Excitation, maximum	15		Vdc or Vac rms
Input impedance	415±15		Ohms
Output impedance	350±3		Ohms
Insulation resistance	>2000		Mega-Ohms
Cable length	1.0		m
Cable type	6 wire, PVC, single floating screen		Standard
Construction	Plated (Anodize) aluminum		
Environmental protection	IP65**		
Platform size (max)	400 x 400		mm
Recommended torque	Up to 30kg: 7.0 50kg & up: 10.0		N·m

\* 1010 is non-balanced load cell (Non-balanced Bridge), 1015 is balanced

\*\* IP67 available upon request

WIRING SCHEMATIC DIAGRAM (1010)  
(unbalanced bridge configuration)

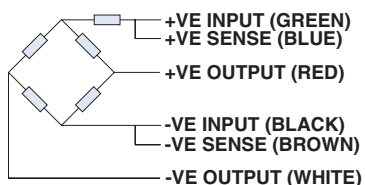

WIRING SCHEMATIC DIAGRAM (1015)

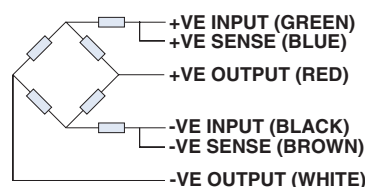

BALANCED TEMPERATURE COMPENSATION

## VISHAY TRANSDUCERS (VT) SALES OFFICES

**VT Americas**  
City of Industry, CA  
PH: +1-626-858-8899  
FAX: +1-626-332-3418  
vt.us@vishaymg.com

**VT Netherlands**  
Breda  
PH: +31-76-548-0700  
FAX: +31-76-541-2854  
vt.nl@vishaymg.com

**VMG UK**  
Basingstoke  
PH: +44-125-646-2131  
FAX: +44-125-647-1441  
vt.uk@vishaymg.com

**VMG Israel**  
Netanya  
PH: +972-9-863-8888  
FAX: +972-9-863-8800  
vt.il@vishaymg.com

**VMG Germany**  
Heilbronn  
PH: +49-7131-3901-260  
FAX: +49-7131-3901-2666  
vt.de@vishaymg.com

**VT China**  
Tianjin  
PH: +86-22-2835-3503  
FAX: +86-22-2835-7261  
vt.prc@vishaymg.com

**VMG France**  
Chartres  
PH: +33-2-37-33-31-20  
FAX: +33-2-37-33-31-29  
vt.fr@vishaymg.com

**VT Taiwan\***  
Taipei  
PH: +886-2-2696-0168  
FAX: +886-2-2696-4965  
vt.roc@vishaymg.com  
\*Asia except China



## Notice

Specifications of the products displayed herein are subject to change without notice. Vishay Intertechnology, Inc., or anyone on its behalf, assumes no responsibility or liability for any errors or inaccuracies.

Information contained herein is intended to provide a product description only. No license, express or implied, by estoppel or otherwise, to any intellectual property rights is granted by this document. Except as provided in Vishay's terms and conditions of sale for such products, Vishay assumes no liability whatsoever, and disclaims any express or implied warranty, relating to sale and/or use of Vishay products including liability or warranties relating to fitness for a particular purpose, merchantability, or infringement of any patent, copyright, or other intellectual property right.

The products shown herein are not designed for use in medical, life-saving, or life-sustaining applications. Customers using or selling these products for use in such applications do so at their own risk and agree to fully indemnify Vishay for any damages resulting from such improper use or sale.